

## MRA/228-128N-203



- MRA/228-128N-203 ring
- To be paired with SMLA bearingless absolute magnetic encoder
- Through hollow shaft  $\varnothing 203$  mm / 7.99"

#### Suitable for the following models:

- MRA/228-128N-203

#### Table of Contents

Preliminary information	5
1 - Safety summary	6
2 - Identification	9
3 - Mounting instructions	10
4 - Electrical information	14
5 - Error and fault diagnostics	15
6 - Maintenance	16
7 - Troubleshooting	18

This publication was produced by Lika Electronic s.r.l. 2020. All rights reserved. Tutti i diritti riservati. Alle Rechte vorbehalten. Todos los derechos reservados. Tous droits réservés.

This document and information contained herein are the property of Lika Electronic s.r.l. and shall not be reproduced in whole or in part without prior written approval of Lika Electronic s.r.l. Translation, reproduction and total or partial modification (photostat copies, film and microfilm included and any other means) are forbidden without written authorisation of Lika Electronic s.r.l.

The information herein is subject to change without notice and should not be construed as a commitment by Lika Electronic s.r.l. Lika Electronic s.r.l. reserves the right to make all modifications at any moments and without forewarning.

This manual is periodically reviewed and revised. As required we suggest checking if a new or updated edition of this document is available at Lika Electronic s.r.l.'s website. Lika Electronic s.r.l. assumes no responsibility for any errors or omissions in this document. Critical evaluation of this manual by the user is welcomed. Your comments assist us in preparation of future documentation, in order to make it as clear and complete as possible. Please send an e-mail to the following address [info@lika.it](mailto:info@lika.it) for submitting your comments, suggestions and criticisms.

The logo for Lika Electronic, featuring the word "lika" in a bold, lowercase, sans-serif font. The letter "i" has a dot above it.

# General contents



<b>User's guide</b> .....	<b>1</b>
<b>General contents</b> .....	<b>3</b>
<b>Typographic and iconographic conventions</b> .....	<b>4</b>
<b>Preliminary information</b> .....	<b>5</b>
<b>1 - Safety summary</b> .....	<b>6</b>
1.1. Safety.....	6
1.2 Electrical safety.....	6
1.3 Mechanical safety.....	6
1.4 Cleaning the polymer-ferrite material.....	7
<b>2 - Identification</b> .....	<b>9</b>
<b>3 - Mounting instructions</b> .....	<b>10</b>
3.1 Overall dimensions.....	10
3.2 Magnetic ring.....	11
3.3 Installing the ring.....	12
3.3.1 Mounting the magnetic ring.....	12
<b>4 - Electrical information</b> .....	<b>14</b>
4.1 Ground connection.....	14
<b>5 - Error and fault diagnostics</b> .....	<b>15</b>
<b>6 - Maintenance</b> .....	<b>16</b>
<b>7 - Troubleshooting</b> .....	<b>18</b>

# Typographic and iconographic conventions

In this guide, to make it easier to understand and read the text the following typographic and iconographic conventions are used:

- parameters and objects both of Lika device and interface are coloured in **GREEN**;
- alarms are coloured in **RED**;
- states are coloured in **FUCSIA**.

When scrolling through the text some icons can be found on the side of the page: they are expressly designed to highlight the parts of the text which are of great interest and significance for the user. Sometimes they are used to warn against dangers or potential sources of danger arising from the use of the device. You are advised to follow strictly the instructions given in this guide in order to guarantee the safety of the user and ensure the performance of the device. In this guide the following symbols are used:

	<p>This icon, followed by the word <b>WARNING</b>, is meant to highlight the parts of the text where information of great significance for the user can be found: user must pay the greatest attention to them! Instructions must be followed strictly in order to guarantee the safety of the user and a correct use of the device. Failure to heed a warning or comply with instructions could lead to personal injury and/or damage to the unit or other equipment.</p>
	<p>This icon, followed by the word <b>NOTE</b>, is meant to highlight the parts of the text where important notes needful for a correct and reliable use of the device can be found. User must pay attention to them! Failure to comply with instructions could cause the equipment to be set wrongly: hence a faulty and improper working of the device could be the consequence.</p>
	<p>This icon is meant to highlight the parts of the text where suggestions useful for making it easier to set the device and optimize performance and reliability can be found. Sometimes this symbol is followed by the word <b>EXAMPLE</b> when instructions for setting parameters are accompanied by examples to clarify the explanation.</p>

# Preliminary information

This guide is designed to provide the most complete and exhaustive information the operator needs to correctly and safely install and operate the **MRA/228-128N-203 magnetic ring**.

The ring must be compulsory paired with the **SMLA bearingless absolute magnetic encoder**. The order code of the paired SMLA encoder must be as follows: SMLA-xxx-xx-xxx-**R5** where R5 = MRA/228-128N-203 ring.

**MRA/228-128N-203** magnetic ring is equipped with one absolute track. The external diameter of the ring is 228 mm / 8.976". The diameter of the through hollow shaft is 203 mm / 7.99". The track is fitted with 128 poles.

## 1 - Safety summary

### 1.1. Safety

- Always adhere to the professional safety and accident prevention regulations applicable to your country during device installation and operation;
- installation and maintenance operations have to be carried out by qualified personnel only, with power supply disconnected and stationary mechanical parts;
- device must be used only for the purpose appropriate to its design: use for purposes other than those for which it has been designed could result in serious personal and/or the environment damage;
- high current, voltage and moving mechanical parts can cause serious or fatal injury;
- failure to comply with these precautions or with specific warnings elsewhere in this manual violates safety standards of design, manufacture, and intended use of the equipment;
- Lika Electronic assumes no liability for the customer's failure to comply with these requirements.

### 1.2 Electrical safety

- Ensure that the ring is connected to ground. Minimize noise by connecting the drive shaft to ground; the ring must be installed as described in this guide, ensure that it is in electrical contact with the drive shaft.

### 1.3 Mechanical safety

- Install the ring following strictly the information in the "3 - Mounting instructions" section on page 10;
- mechanical installation has to be carried out with stationary mechanical parts;
- do not disassemble the unit unless otherwise indicated;
- do not tool or drill the unit, do not tamper with the unit;
- do not subject the device to knocks;
- protect the unit against acid solutions or chemicals that may damage it;
- respect the environmental characteristics of the product, use the product according to the indicated degree of IP protection;
- we suggest installing the unit providing protection means against waste, especially swarf as turnings, chips, or filings; should this not be possible, please make sure that adequate cleaning measures (as for instance brushes, scrapers, jets of compressed air, etc.) are in place in order to prevent the sensor and the magnetic ring from jamming.



#### CAUTION

Keep magnets away from the ring, it could be damaged by strong magnetic fields.

1.4 Cleaning the polymer-ferrite material

Should the polymer-ferrite material require surface cleaning, we suggest using a soft and clean cloth with 50:50 mixture of isopropyl alcohol (IPA) and water (rubbing alcohol), then wait for the surface to dry.



**WARNING**

- Access to the equipment must be limited or prevented in order to avoid charging or discharging electrostatic charges.
- In order to prevent the accumulation of electrostatic charges while cleaning the equipment, the unit (and especially the magnetic tape of the ring and any other non metallic part that is exposed) must be cleaned only with a damp cloth or a cloth soaked in a damp solution; compressed air cannot be used. Any rubbing with non-conductive materials must be strictly avoided.
- Any other step intended to avoid electrostatic charging and/or discharging must be taken in compliance with all local provisions and national regulations as well as the relevant safety regulations and in particular the EN 60079-0 directive and the EN 60079-14 directive.



**WARNING**

Protect the ring from acid solutions and chemicals that may damage it. Please check in the following table the chemicals that have no or low impact, the chemicals that have low to medium impact and the chemicals that have high impact on the magnetic material of the tape.

No or low impact chemicals		
Acetic acid 20%	Acetic acid 30%	Cotton seed oil
Formaldehyde 40%	Formic acid	Glacial acetic acid
Glycerine (93°C)	Hexane	Isooctane
Kerosene	Lactic acid	Linseed oil
Mineral oil	Oleic acid	Soy bean oil
Steam heat	Stearic acid	
Low to medium impact chemicals		
Acetone	Acetylene	Anhydrous ammonia
Isopropyl ether	Lacquer solvent	Petrol
Seawater	Turpentine	
High impact chemicals		
Benzene	Carbon tetrachloride	Hydrochloric acid 37% (93°C)
Nitric acid 70%	Nitrobenzene	Red fuming nitric acid
Tetrahydrofuran	Toluene	Trichloroethylene

Xylene		
--------	--	--

**NOTE**

Tolerances also depend on temperature, air supply, duration of impact, liquid consistency, and several other factors. Therefore it is always advisable to test the material under real conditions.



## 2 - Identification

Device can be identified through the **order code** and the **serial number** printed on the label applied to its body. Information is listed in the delivery document too. Please always quote the order code and the serial number when reaching Lika Electronic for purchasing spare parts or needing assistance. For any information on the technical characteristics of the product refer to the technical datasheet.



**Warning:** devices having order code ending with "/Sxxx" may have mechanical characteristics different from standard and be supplied with additional documentation (Technical Info).

### 3 - Mounting instructions



**WARNING**

Installation must be carried out by qualified personnel only, with power supply disconnected and mechanical parts compulsorily in stop.



**WARNING**

Install the unit providing protection means against waste, especially swarf as turnings, chips or filings; should this not be possible, please make sure that adequate cleaning measures (as for instance brushes, scrapers, jets of compressed air, etc.) are in place in order to prevent the sensor and the magnetic ring from jamming.

Make sure the mechanical installation meets the system's requirements for both the sensor and the ring indicated in this guide.

#### 3.1 Overall dimensions

(values are expressed in mm)

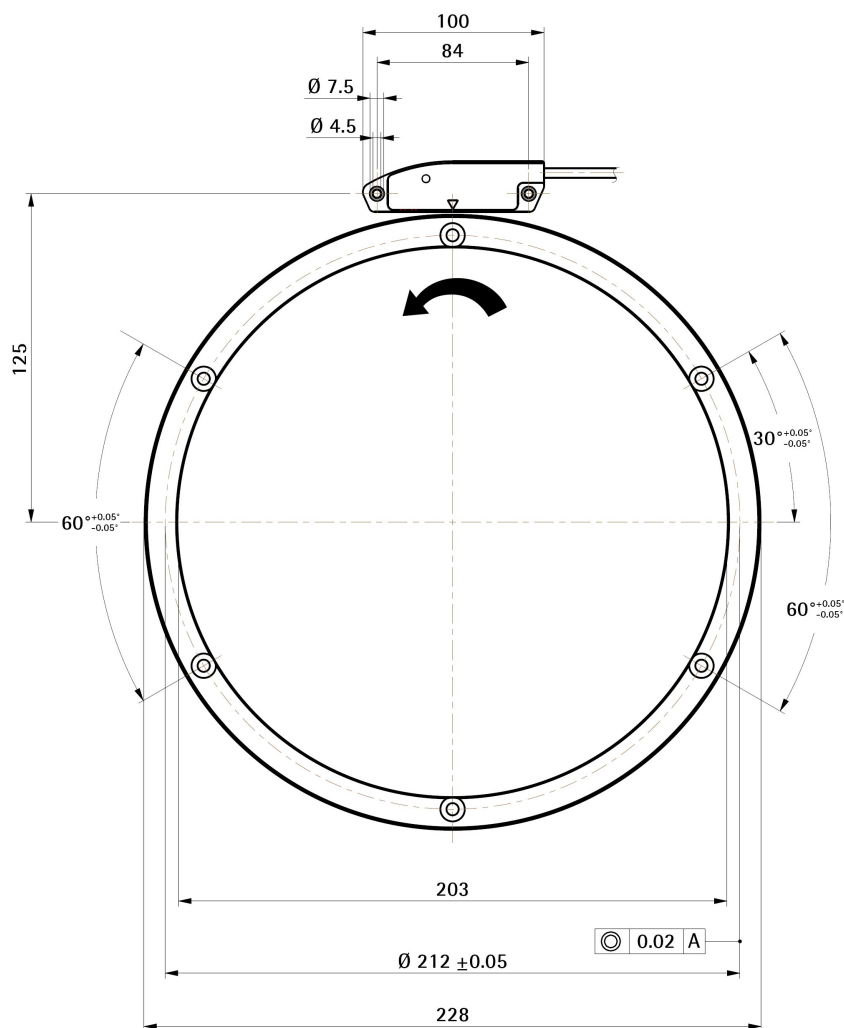

Figure 1 - Overall dimensions of the measuring system

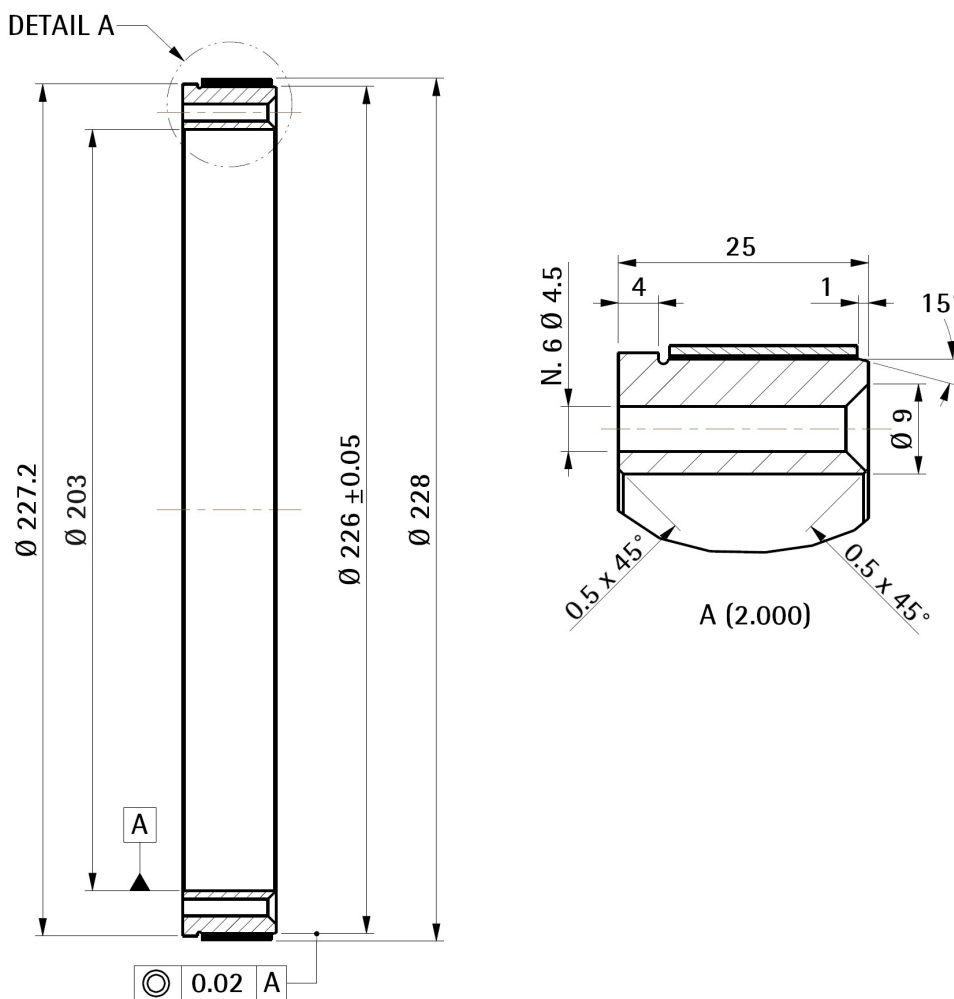

Figure 2 - Lateral views

### 3.2 Magnetic ring

It is mandatory to pair the **MRA/228-128N-203 magnetic ring** with the **SMLA-...** sensor. The order code of the paired SMLA encoder must be as follows: SMLA-xxx-xx-xxx-**R5** where R5 = MRA/228-128N-203 ring.

Figure 1 and Figure 3 show how the sensor and the magnetic ring must be installed; the arrow indicates the **standard counting direction**, i.e. count is up when the ring turns in the direction indicated by the arrow.



**WARNING**

The system cannot operate if mounted otherwise than illustrated in Figure 1 and Figure 3. Please mind the direction of the cable outlet.



**WARNING**

To minimize noise the drive shaft must be connected to ground and the ring must be in electrical contact with the drive shaft. For PE connection please refer to the "4.1 Ground connection" section on page 14.

### 3.3 Installing the ring

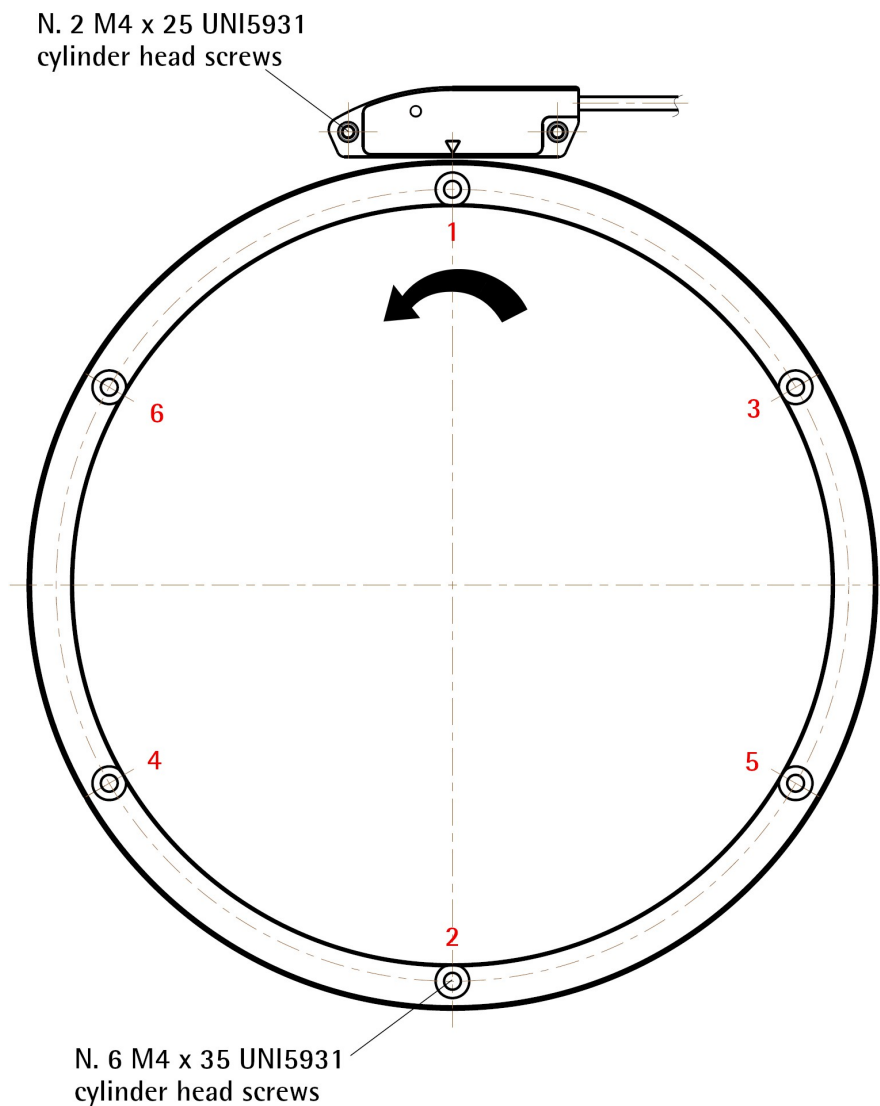

Figure 3 - Installing the ring

#### 3.3.1 Mounting the magnetic ring

1. Mount the magnetic ring on the motor shaft;
2. fasten the ring to the motor shaft by using six cylinder head screws type M4 x 35 UNI5931;
3. tighten the screws following the sequence indicated in the Figure. Recommended tightening torque: **2.5 Nm**.



#### NOTE

For complete information on installing the SMLA encoder please refer to the specific documentation.

**WARNING**

Mount the sensor as shown in the Figures. Please mind the direction of the cable outlet. The system cannot operate if mounted otherwise than illustrated in the Figures.

**WARNING**

The arrow in Figure 1 and Figure 3 is intended to indicate the **standard counting direction**, i.e. count is up when the ring turns in the direction indicated by the arrow.

**WARNING**

After having installed the sensor on the magnetic ring a zero/preset setting operation is compulsorily required. The zero/preset setting operation is further required every time either the sensor or the ring are replaced. For any information on the zero/preset setting operation please refer to the specific documentation of the SMLA encoder.

## 4 – Electrical information

**WARNING**

Electrical connection must be carried out by qualified personnel only, with power supply disconnected and mechanical parts compulsorily in stop.

### 4.1 Ground connection

Ensure that the ring is connected to ground. Minimize noise by connecting the drive shaft to ground; the ring must be installed as described in this guide, ensure that it is in electrical contact with the drive shaft.

**WARNING**

We suggest that the minimum size of the protective earthing (PE) conductor connection is 4 mm<sup>2</sup>.

## 5 - Error and fault diagnostics

At power on or during operation the following errors may occur:

- when switching on the system an alarm is triggered through the diagnostic LED and/or the dedicated bit: the ring is not read correctly; it may be due to one of the following reasons: the ring and/or the sensor are not mounted properly (see the "3 - Mounting instructions" section on page 10); the ring magnetic surface is damaged somewhere; as soon as the problem is solved the error bit switches to high logic level;
- during operation an alarm is triggered through the diagnostic LED and/or the dedicated bit: as previously stated, the ring is not read correctly; it may be due to one of the following reasons: the ring and/or the sensor are not mounted properly (see the "3 - Mounting instructions" section on page 10); the ring magnetic surface is damaged somewhere.

For any further information refer also to the "7 - Troubleshooting" section on page 18.

## 6 - Maintenance



### WARNING

Maintenance operations have to be carried out by qualified personnel only, with power supply disconnected and mechanical parts compulsorily in stop.

The magnetic measurement system does not need any special maintenance; anyway it has to be handled with the utmost care as any delicate electronic equipment. From time to time we recommend the following operations:

- periodically check the soundness of the structure and make sure that there are no loose screws; tighten them if necessary;
- check the gap between the sensor and the magnetic ring. The wear of the machine may increase the tolerances;
- the surface of the magnetic ring has to be regularly cleaned using a soft and clean cloth to remove dust, chips, moisture etc.

Should the polymer-ferrite material require surface cleaning, we suggest using a soft and clean cloth with 50:50 mixture of isopropyl alcohol (IPA) and water (rubbing alcohol), then wait for the surface to dry.



### WARNING

- Access to the equipment must be limited or prevented in order to avoid charging or discharging electrostatic charges.
- In order to prevent the accumulation of electrostatic charges while cleaning the equipment, the unit (and especially the magnetic tape of the ring and any other non metallic part that is exposed) must be cleaned only with a damp cloth or a cloth soaked in a damp solution; compressed air cannot be used. Any rubbing with non-conductive materials must be strictly avoided.
- Any other step intended to avoid electrostatic charging and/or discharging must be taken in compliance with all local provisions and national regulations as well as the relevant safety regulations and in particular the EN 60079-0 directive and the EN 60079-14 directive.



### WARNING

Protect the ring from acid solutions and chemicals that may damage it. Please check in the following table the chemicals that have no or low impact, the chemicals that have low to medium impact and the chemicals that have high impact on the magnetic material of the tape.

No or low impact chemicals		
Acetic acid 20%	Acetic acid 30%	Cotton seed oil
Formaldehyde 40%	Formic acid	Glacial acetic acid
Glycerine (93°C)	Hexane	Isooctane



Kerosene	Lactic acid	Linseed oil
Mineral oil	Oleic acid	Soy bean oil
Steam heat	Stearic acid	
<b>Low to medium impact chemicals</b>		
Acetone	Acetylene	Anhydrous ammonia
Isopropyl ether	Lacquer solvent	Petrol
Seawater	Turpentine	
<b>High impact chemicals</b>		
Benzene	Carbon tetrachloride	Hydrochloric acid 37% (93°C)
Nitric acid 70%	Nitrobenzene	Red fuming nitric acid
Tetrahydrofuran	Toluene	Trichloroethylene
Xylene		



**NOTE**

Tolerances also depend on temperature, air supply, duration of impact, liquid consistency, and several other factors. Therefore it is always advisable to test the material under real conditions.

## 7 - Troubleshooting

The following list shows some typical faults that may occur during installation and operation of the magnetic measurement system.

**Fault:**

The system does not work (no pulse output).

**Possible cause:**

- The ring and/or the sensor are not installed properly. The ring and the sensor need to be coupled as explained in the mounting instructions. The system cannot operate if mounted otherwise. For correct installation please refer to the "3 - Mounting instructions" section on page 10.
- Installation does not meet the mounting tolerances between the sensor and the ring indicated in this guide; the sensor hits the surface of the ring or is too close to/far from it. Check whether the sensor sensitive part is damaged.
- A magnetic part has been placed between the sensor and the magnetic surface of the ring.

**Fault:**

The measured values are either inaccurate or not provided in the whole circumference of the ring.

**Possible cause:**

- The sensor is not installed properly on the ring. See the "3 - Mounting instructions" section on page 10.
- A section of the magnetic surface has been damaged mechanically or magnetically; this may cause a failure to read the position or a position calculation error so that the resulting position value is invalid.
- The measuring error is caused by a torsion or plays in the machine structure. Check for movements in the mechanics of the machine.

This page intentionally left blank

Document release	Release date	Description	HW	SW	Interface
1.0	07.02.2020	First issue	-	-	-



Dispose separately

**lika**

**Lika Electronic**

Via S. Lorenzo, 25 • 36010 Carrè (VI) • Italy

Tel. +39 0445 806600

Fax +39 0445 806699



info@lika.biz • www.lika.biz